

SEE DETAIL B

PATTERN: 3" DIAGONAL

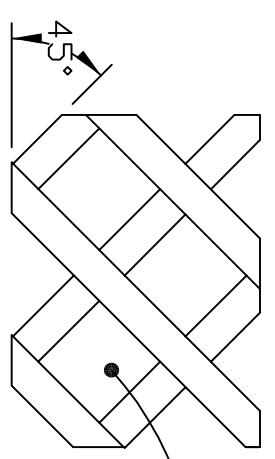

DETAIL A  
N.T.S.

3" x 3" SQUARE

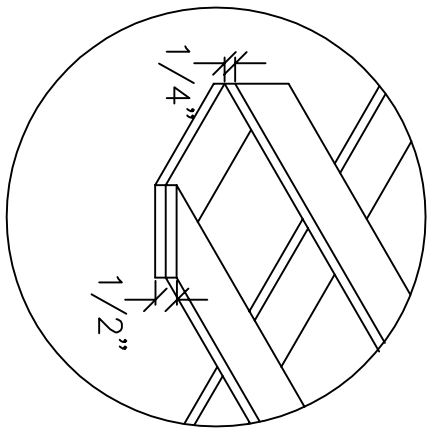

DETAIL B  
N.T.S.

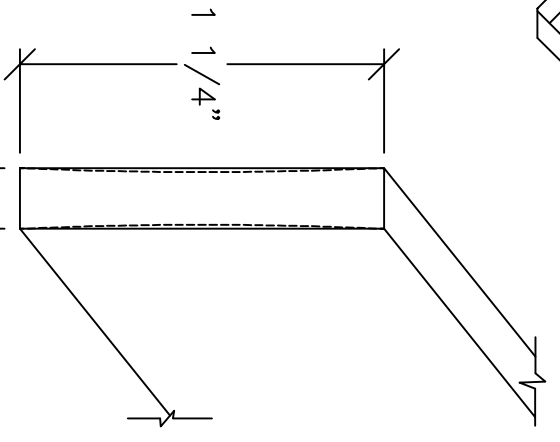

DETAIL C  
N.T.S.

NOTE: PATTERN ALSO AVAILABLE IN 4'x6' SHEETS

REVISIONS:

**PERMALATT PRODUCTS, INC.**

**3462 US 6E, BREMEN, IN 46506**

MODEL:	3" DIAGONAL	TITLE:	DuraShell® VINYL LATTICE	SCALE:	N.T.S.	APPROVED BY:	EH
TREARBO3				DATE:	10/19/98	PROJECT NO.:	
				DRAWN BY:	TH	DRAWING NO.:	1